



Assessment of biomass residue availability and bioenergy yields in Ghana



Francis Kemausuor^{a,*}, Andreas Kamp^b, Sune Tjalfe Thomsen^b,
Edem Cudjoe Bensah^{c,d}, Hanne Østergård^b

^a Department of Agricultural Engineering, KNUST, Kumasi, Ghana

^b Department of Chemical and Biochemical Engineering, Technical University of Denmark, DTU, DK-2800 Kongens Lyngby, Denmark

^c Department of Chemical Engineering, Kumasi Polytechnic, Kumasi, Ghana

^d Department of Chemical Engineering, KNUST, Kumasi, Ghana

ARTICLE INFO

Article history:

Received 3 July 2013

Received in revised form 29 January 2014

Accepted 29 January 2014

Available online 28 February 2014

Keywords:

Biomass

Bioenergy

Biogas

Cellulosic ethanol

Ghana

ABSTRACT

Biomass is an important renewable energy source that holds large potential as feedstock for the production of different energy carriers in a context of sustainable development, peak oil and climate change. In developing countries, biomass already supplies the bulk of energy services and future use is expected to increase with more efficient applications, such as the production of biogas and liquid biofuels for cooking, transportation and the generation of power. The aim of this study is to establish the amount of Ghana's energy demand that can be satisfied by using the country's crop residues, animal manure, logging residues and municipal waste. The study finds that the technical potential of bioenergy from these sources is 96 PJ in 2700 Mm³ of biogas or 52 PJ in 2300 ML of cellulosic ethanol. The biogas potential is sufficient to replace more than a quarter of Ghana's present woodfuel use. If instead converted to cellulosic ethanol, the estimated potential is seven times the estimated 336 ML of biofuels needed to achieve the projected 10% biofuels blends at the national level in 2020. Utilizing the calculated potentials involves a large challenge in terms of infrastructure requirements, quantified to hundreds of thousands of small-scale plants.

© 2014 Elsevier B.V. All rights reserved.

1. Introduction

Biomass is a renewable energy resource derived from living or recently living organisms (Fernandes and Costa, 2010). Biomass is today a very important energy source and forecasts for energy consumption suggest that it has a pivotal role to play as it can drastically reduce greenhouse gas¹ emissions compared to fossil fuels if produced sustainably (IEA Bioenergy, 2008; IEA, 2012). In developing countries, biomass already supplies the bulk of energy services albeit in very inefficient forms, particularly as firewood and charcoal for cooking and heating. Future use of biomass is expected to entail more efficient applications, such as the production of biogas and liquid fuels for cooking, transportation and the generation of power. Many of the available studies on utilizing biomass for energy have targeted global and/or regional level assessments (e.g. Dasappa, 2011; Smeets et al., 2007) while others

have targeted specific countries (see Cai et al., 2008; Kludze et al., 2010). The use of biomass residues, especially, for the production of non-food based biofuels is seen as a positive way to mitigate the effects of climate change (Gustavsson et al., 2007).

In the last few years, several countries with high agricultural potentials have sought to use their agricultural resources for the production of biofuels to limit the local use of fossil fuels and/or for export. Notable economic success stories are from Brazil, United States (US), Malaysia and Indonesia (Lamers et al., 2011). However, there have been criticisms of the use of agricultural land for the production of energy crops because of consequent direct or indirect effects of deforestation and increases in food prices (IEA, 2010). This has encouraged research toward biofuels that are based on lignocellulose in nonedible plant materials, typically in agricultural residues, and on residues and waste from other economic sectors. The bulk of residue-based biofuels (used throughout to refer to biofuels based on agricultural and forestry residues, manure and municipal waste) is expected to be produced from agricultural residues, reducing the negative effects of using cropland to produce biofuels instead of food. Political targets promote this development, particularly in the US and EU, through incentives for domestic production- and consumption targets that encourage production (US Government, 2007; EU, 2009). The EU Commission

* Corresponding author. Tel.: +233 207457532.

E-mail addresses: fkemausuor.soe@knust.edu.gh, Kemausuor@gmail.com (F. Kemausuor).

¹ Greenhouse gases are gases that trap heat in the atmosphere. These gases include carbon dioxide and methane.

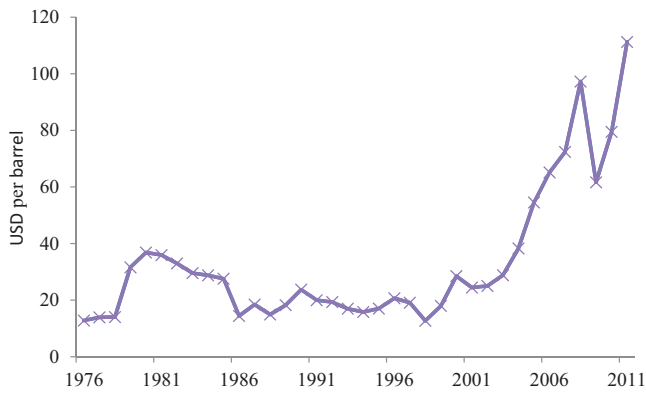

Fig. 1. Historical Brent crude oil prices (nominal prices).

Source: Data from BP (2012).

has published a proposal to limit the use of food-based biofuels to meet its 10% 'renewable energy for transport' target to only 5% with the rest expected to come from non-food based sources (EU, 2012).

Though Ghana is an emerging oil producer, oil reserves will be depleted in the foreseeable future and it is prudent that alternative and more renewable energy sources are identified and made available. According to early estimates, current oil production wells in Ghana could run out by about 2040 (Edjekumhene et al., 2010) but additional discoveries have since been made which could extend this date. Globally, oil reserves are dwindling due to the combination of population growth, urbanization, and increasing per capita energy consumption. As a result, crude oil prices are rising (Fig. 1) with implications for economies that are highly dependent on it. The irregularities in oil supplies and distributions, the challenges of accessing and procuring unconventional oil, and occasional political instabilities in oil producing nations in the developing world have caused general uncertainty regarding global reliability on oil, and have spurred renewed interest in renewable energy (IEA, 2012). Moreover, combustion of fossil fuels contributes to global warming (IPCC, 2007).

In view of the above, there is renewed interest in Ghana to further develop capacity in alternatives to fossil energy sources and thus (1) reduce the national carbon footprint, (2) reduce the country's dependence on oil, and (3) pursue political and economic goals through utilizing presently under-utilized and domestically available resources. Present political momentum is indicated by the development of key documents such as the Strategic National Energy Plan (SNEP) of 2006 (Energy Commission, 2006), the draft Bioenergy Policy of 2011 (Energy Commission, 2011a), and the Renewable Energy Law of 2011 (Ministry of Energy, 2012). Based on these documents, bioenergy is expected to contribute significantly to renewable energy supply from Ghana's energy sector. In order to pursue a strategy of increased bioenergy production while avoiding some of the problems associated with direct or indirect effects on food availability and deforestation rates, it makes sense for Ghana to explore its potentials for residue-based biofuels. This could make it possible for residue-based biofuels to contribute toward the proposed targets for all types of biofuels. Energy potentials from agricultural residues, logging residues, agro-industrial residues, municipal solid waste, food industry waste, industrial wastewater and animal waste could be explored for present and future energy needs.

Production of biofuels based on the mentioned residues avoids the problem of competition over land with food production. Residue-based biofuels, however, are not automatically environmentally benign nor do they ensure the development of a sustainable energy supply. To mention a couple of issues, the sustainability of feedstock supply is influenced by biomass production

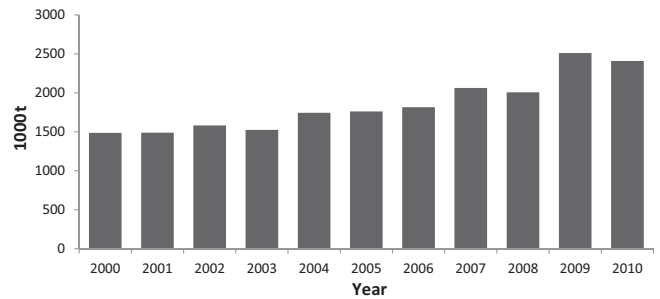

Fig. 2. Petroleum products consumption (Energy Commission, 2011b).

methods, and the transport and conversion of biomass into bioenergy requires additional inputs. Biomass production, transport and conversion are all likely to depend on non-renewable resources. Furthermore, the use of any biomass for fuel production entails a net loss of nutrients from the biomass production site that may cause a systematic deterioration of soil quality. These and similar issues require thorough assessment to avoid the substitution of one set of problems with another set of problems (Gopalakrishnan et al., 2009).

Bioenergy production in Ghana could be more than a means to reach present and short-term energy demands and politically established production targets; bioenergy could be a cornerstone of sustainable development. Therefore, the ability of specific bioenergy projects to sustain themselves over time and through changes in the surrounding environmental, social and economic context should be evaluated before decisions on which projects to develop further are made.

This paper assesses the potentials for bioenergy (biogas and cellulosic ethanol) to meet energy requirements in Ghana using residues and waste as feedstock. Important questions addressed in this paper include: (1) Which resources are available and how much is retrievable? (2) What amount of Ghana's projected energy demand can be satisfied by utilizing the country's crop residues, animal manure, logging residues and municipal solid waste?

2. Present and projected energy consumption and production

At the end of 2010, the energy consumption of Ghana was: 2.4 Mt of petroleum products² (equivalent to 111 PJ liquid fuel energy), 6860 GWh of electricity (equivalent to 25 PJ electrical energy) and about 18 Mt of woodfuel (equivalent to 360 PJ of thermal energy, assuming 20 GJ/t of wood) (Energy Commission, 2011b). Even though animal manure is used to some extent in the northern parts of the country, its use is minimal (Arthur et al., 2011). There is currently no commercial production of liquid biofuels in the country. About 200 household and institutional biogas plants were estimated to have been installed at the end of 2009, out of which less than half were functioning (Bensah and Brew-Hammond, 2010).

Petroleum products dominate commercial fuels in Ghana and consumption has been growing over time. In the last decade alone, petroleum consumption increased 60% from 1.5 Mt (69 PJ) in 2000 to 2.4 Mt (111 PJ) in 2010 (Fig. 2). Even though Ghana is producing oil and is likely to benefit from some of the effects of high oil prices, this luxury may be short lived as oil drilling activities in the country are not expected to go beyond the year 2040, even at a low production peak of 250,000 barrels per day (approximately 558 PJ/year)

² Petroleum products refer to refined petroleum fuels such as gasoline and diesel. It does not include crude oil used for electricity generation.

Table 1
Historical and projected use of woodfuel, petroleum products and electricity in Ghana.

Energy carriers	Unit	2000	2015	2020
Woodfuel, mass	Mt	14	38–46	54–66
Woodfuel, thermal energy equivalents	PJ	280	760–920	1080–1320
Petroleum products, mass	Mt	1.6	3	4.5
Petroleum products, liquid energy equivalents	PJ	74	139	208
Electricity ^a	GWh	6900	18,000	24,000

Source: Modified from Energy Commission (2006).

^a Excludes transmission and distribution losses.

unless new reserves are discovered (Edjekumhene et al., 2010). Comparing consumption levels up until 2020 (Table 1) with the suggested oil production peak, the need for replacing petroleum-based fuels with biofuels does not seem imminent. It must be understood, however, that the majority of oil being produced in Ghana is produced by foreign companies and leaves the country for export, never seeing the Ghanaian market. Moreover, in a longer perspective it seems prudent to develop the country's bioenergy sector. As noted by Hirsch et al. (2005), the time needed for preparing for and transition to a post-peak oil situation is counted in decades.

Traditionally, Ghana's electricity production has come from two hydropower dams (Akosombo and Kpong dams) which together contributed 69% to the over 10,000 GWh total electricity generated in 2010. From just 8% in 2000, electricity from thermal plants, driven by petroleum fuels, contributed 31% to electricity generation in 2010. With the increase in electricity demand and poor rainfall experienced in recent years, the share of electricity from thermal plants is expected to increase significantly (GRIDCO, 2011).

Various projections conducted by the Ghanaian Ministry of Energy and its agencies (Energy Commission, 2006) suggest that energy demand will increase for all sectors of the economy in line with future economic growth (Table 1). In view of the demand for petroleum resources and mindful of the environmental impacts of increased consumption of petroleum fuels, the Strategic National Energy Plan 2006–2020 and the draft bioenergy policy call for 10 and 20% substitution of national petroleum fuels consumption with biofuels by 2020 and 2030, respectively (Energy Commission, 2006, 2011a). According to Antwi et al. (2010), Ghana would have to produce roughly 336 ML of biofuels to substitute 10 per cent of expected transport fuels in 2020. Besides transportation, there is also the potential to replace portions of cooking fuel use (especially firewood and charcoal) with biogas that is much more efficient at the point of use. Demand for woodfuel is projected to increase steadily to more than 50 Mt in 2020, creating a worrying situation because of the resulting net increase in forest degradation, averaging about 115,000 ha/yr during the period 2000–2005 (FAO, 2010). In order to reduce woodfuel usage and hence reduce the rate of forest degradation, biogas for cooking should be encouraged and implemented with locally produced biogas. In the following, we will estimate the potential for replacing petroleum-based transport fuel and woodfuel use with cellulosic ethanol and biogas, respectively. The possibility of converting biogas into electricity remains, albeit with considerable conversion loss. The production of electricity has not been elaborated on in this paper.

3. Methodology

The estimation of available biomass residues in Ghana and bioenergy potentials was based on detailed computations using published literature when possible. In the cases where no scientifically solid data were available for the computations, assumptions have been made which will appear in the specific cases. Fig. 3 illustrates how the residue- and energy potentials were obtained. Different productions (p), yields (y), concentrations (c), and

efficiencies (η) are indicated. Table 2 explains the indices used in Fig. 3. In the following sections the calculations will be elaborated on.

3.1. Estimation of crop residue potentials

The estimation of residue potentials can be done in several ways, according to different types of potential. These include theoretical, technical, economic, implementation and sustainable biomass residue potentials (Biomass Energy Europe, 2010). The theoretical potential is the most straightforward to estimate since it takes into consideration all biomass that is available for collection and use and can be based on available crop production statistics. In practice, however, not all the biomass may be available for collection and use due to different inhibiting, economic, social and environmental factors. In this paper, we assess the theoretical and the technical potentials. The technical potential is the fraction of the theoretical potential that is technically recoverable. Due to the unavailability of data, we are unable to estimate beyond the technical potential. Thus, the economic, implementation and sustainable biomass potentials, which should be much lower, are not estimated in this paper. The estimated potential should be regarded as the maximum that could be obtained based on current technology.

The main agricultural crops in Ghana, in terms of area cultivated and production capacity, are cocoa, maize, cassava, yam, oil palm, groundnut, plantain, sorghum, cocoyam and rice (MOFA, 2011). Residues produced from these crops, relevant to bioenergy are the straw, stalk, husks, trunks and sometimes their peels after harvesting and/or processing. The theoretical potential of crop residues was estimated using the output of crops multiplied by the residue to product ratio (y_{RPR}). There are y_{RPR} values for crop types grown in Ghana but these are from different test fields and regions making accurate computation difficult (Duku et al., 2011; Jekayinfa and Scholz, 2009; Kartha and Larson, 2000; Koopmans and Koppejan, 1997). Some parameters that may vary from farm to farm include moisture content at time of measurement, yield of crops, and yield of biomass, which all depend on climatic conditions and the level of management. The computation for this assessment was done using the mean value from three different sources of y_{RPR} (Table 3).

Following the example of previous studies (Lemke et al., 2010; Zheng et al., 2010) we use a recoverability fraction (y_{RF}) to estimate the technical potential (Table 3). The y_{RF} is the ratio between the residues that realistically can be collected and the total production of residues (the theoretical potential) (Smeets et al., 2007). The y_{RF} differs according to crop type, soil type, typical weather conditions, and the tillage system used. To the best of our knowledge, no study has established the y_{RF} for agricultural crops in Ghana. Doing so would demand a detailed procedure as described by Kludze et al. (2010), which is beyond the scope of this paper. The y_{RF} used in other assessments varies from one study to the other. In a global assessment of bioenergy potentials, Smeets et al. (2004) used an y_{RF} of 25% for rice straw, 80% for stalks, 100% for processing residue and 50% for wood process residues. In an earlier assessment of maize residues for energy production in the Eastern region of Ghana, the Kumasi Institute for Technology, Energy and Environment (KITE,

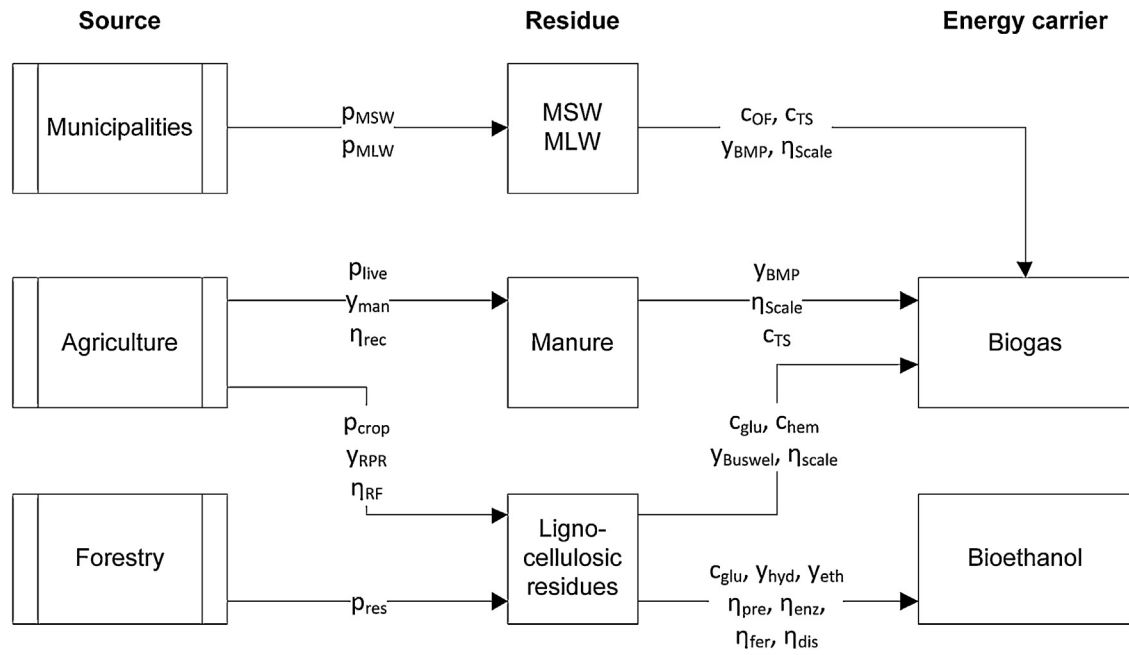

Fig. 3. Computations of biogas and ethanol yields from Ghanaian biomass residues. Productions (p), yields (y), concentrations (c), and efficiencies (η) are indicated. The various indices are presented in Table 2.

2009) used 80% y_{RF} taking into consideration the fact that farming in Ghana is largely no-tillage and with no existing regulation for residue management. In this paper, we assume recoverability fractions based on previous studies to estimate the technical biomass potential.

3.2. Estimation of animal manure, wood residues and municipal solid and liquid waste (MSW and MLW)

The potential quantities of animal manure resources are estimated using number of animals, average annual manure production per animal, coefficient of manure collection and dry manure fraction (Cai et al., 2008). Amount of manure per head per day depends on factors such as body size, kind of feed, physiological state (lactating, growing, etc.), and level of nutrition (Junfeng et al., 2005). The manure theoretically available was estimated by

multiplying the number of animals (p_{live}) by the estimated manure produced per day (y_{man}). Data on animal production was obtained from the Ghanaian Ministry of Food and Agriculture (MOFA, 2011). The recoverability fraction used in the estimation of technically available animal manure is based on a study by KITE (2008).

Wood residue results as a co-product of logging and timber processing. Wood residue can be collected and used from in-forest cutover, log landing or wood processing sites. In Ghana, the landing and processing sites are often the same since the tree-length materials are transported straight from the forest to the processing sites. Data on wood production was obtained from the FAO (2012). The data obtained is categorized into slabs, wane, bark and sawdust.

With regard to MSW, data was collected only for the regional capitals and other major cities. These cities were considered because of relatively higher population and therefore higher generation of solid and liquid waste and better waste collection systems

Table 2
Indices of productions (p), yields (y), concentrations (c), and efficiencies (η) used in the determination of biogas and ethanol yields from Ghanaian biomass residues.

Index	Explanation	Unit
C_{glu}	The concentration of glucan (cellulose or starch) in a specific residue	g/100 g TS
C_{chem}	The concentration of hemicellulose in a specific residue	g/100 g TS
C_{OF}	The concentration of the organic fraction in MSW	g/100 g TS
C_{TS}	Total solids concentration	g TS/100 g
p_{crop}	The production of specific crop residues annually	t TS/yr
p_{live}	Number of specific livestock populations	heads
p_{MLW}	Production of municipal liquid waste	t TS/yr
p_{MSW}	Production of municipal solid waste	t TS/yr
p_{res}	The annual production of forestry residuals	t TS/yr
y_{BMP}	Biomethane potentials – from literature	$m^3 CH_4/kg TS$
y_{Buswel}	Biomethane potentials–calculated with Buswel’s formula	$m^3 CH_4/kg TS$
y_{eth}	Ethanol stoichiometric yield from glucose	g/g
y_{hyd}	Glucose yield when enzymatic hydrolysed from glucan	g/g
y_{man}	Manure produced of one specific livestock annually	kg/yr/head
y_{RPR}	Residue to product ratio	w/w
y_{RF}	Recoverability fraction	w/w
η_{enz}	Efficiency of enzymatic conversion (cellulose converted)	%
η_{pre}	Efficiency of pretreatment (glucose conserved)	%
η_{rec}	Recoverability of manure for specific livestock	%
η_{scale}	The average efficiency of continuous biogas production compared with BMP (depending of reference of BMP)	%

TS is total solids.

Table 3
Indices for specific agricultural and forestry residues.

Crop	Residue	P_{crop} (P_{res}) MtTS/yr	(Y_{RF}) g/g	Y_{RPR} ^a g/g	Y_{BUSWEL} m ³ CH ₄ /kg TS
Maize	Stalks ^F	1.7	0.80	1.59 ^{a,b,c}	0.268
	Husks ^P	1.7	1.00	0.20 ^b	0.238
	Cobs ^P	1.7	1.00	0.29 ^{b,c}	0.348
Rice	Straw ^F	0.47	0.25	1.66 ^{a,b,c}	0.264
	Husks ^P	0.47	1.00	0.26 ^{b,c}	0.232
Millet	Stalks ^F	0.18	0.80	1.83 ^{a,b,c}	0.181
Sorghum	Straw ^F	0.29	0.80	1.99 ^{b,c}	0.285
Groundnut	Shells ^P	0.48	1.00	0.37 ^{b,c}	0.227
	Straw ^P	0.48	1.00	2.15 ^{b,c}	0.154
Cowpea	Shells ^P	0.24	1.00	1.75 ^b	0.065
Cassava	Stalk ^F	14	0.80	0.06 ^b	0.192
	Peelings ^P	14	0.20	0.25 ^b	0.323
Plantain	Trunks and leaves ^F	3.7	0.80	0.50 ^c	0.213
Soybean	Straw and pods ^F	0.16	0.80	3.50 ^b	0.225
Yam	Straw ^F	5.9	0.80	0.50 ^c	0.167
Cocoyam	Straw ^F	1.3	0.80	0.50 ^c	0.167
Sweet potato	Straw ^F	0.044	0.80	0.50 ^b	0.144
Oil palm	EFB ^P	2.0	1.00	0.17 ^{a,b}	0.253
	Kernel shells ^P	2.0	1.00	0.07 ^b	0.280
Coconut	Fibre ^P	2.0	1.00	0.14 ^b	0.146
	Husks ^P	0.30	1.00	0.42 ^b	0.141
	Shells ^P	0.30	1.00	0.25 ^{a,b,c}	0.289
Sugarcane	Leaves ^F	0.15	0.80	0.11 ^{a,b,c}	0.204
	Bagasse ^P	0.15	1.00	0.18 ^{b,c}	0.221
Cotton	Stalks ^F	0.027	0.80	2.88 ^{b,c}	0.225
Cocoa	Pods ^F	0.90	0.80	0.93 ^{a,b}	0.080
	Slabs ^P	(0.093)	1.00	–	0.276
	Wane ^P	(0.035)	1.00	–	0.276
Forestry	Bark ^P	(0.017)	1.00	–	0.159
	Sawdust ^P	(0.038)	1.00	–	0.218

^F indicates a field based residue while ^P indicates a processing residue.

^a Average based on literature sources.

^a Duku et al. (2011).

^b Jekayinfa and Scholz (2009).

^c Kartha and Larson (2000).

as compared to other locations in the country. Besides, there is poor data on waste management activities outside the major cities. The possibility of collecting and using MSW from a number of smaller towns is not being ruled out but the possible contribution from this has not been considered in this paper.

3.3. Estimation of energy potentials

Eq. (1) shows the formula for the computation of annual potential biogas production from MSW (in m³ methane per yr). Here the yield of biogas ($y_{biogas}(MSW)$) is equal to the production of municipal solid waste (p_{MSW}) multiplied by the concentration of the organic fraction in MSW ($C_{OF} = 64\%$) (Asase et al., 2009), the total solids concentration in the organic fraction of MSW (C_{TS}) (Unpublished results from Accra, Ghana), and the biomethane potentials of organic fraction of MSW ($y_{BMP} = 0.32$ m³ CH₄/kg TS) based on an average of continuous mesophilic biogas plants from Gunaseelan (1997).

$$y_{biogas}(MSW) = p_{MSW} \cdot C_{OF} \cdot C_{TS} \cdot y_{BMP} \quad (1)$$

Similarly, Eq. (2) describes the computations of the biogas potentials from municipal liquid waste (MLW). In Eq. (2) the total solids concentration in the organic fraction of MLW (C_{TS}) equals 8.9 g TS/100 g, and the biomethane potential (y_{BMP}) of MLW is assumed to be 0.34 m³ CH₄/kg TS (Arthur and Brew-Hammond, 2010). Eq. (3) describes the computation of biogas potentials from livestock manure. The indices are presented in Table 4.

$$y_{biogas}(MLW) = p_{MLW} \cdot C_{TS} \cdot y_{BMP} \quad (2)$$

$$y_{biogas}(manure) = p_{live} \cdot y_{man} \cdot \eta_{rec} \cdot C_{TS} \cdot y_{BMP} \quad (3)$$

The computations of the potential biogas produced from lignocellulosic residues from agriculture or forestry is described in Eq. (4). The y_{BUSWEL} is calculated from compositional data from literature which is compiled in Appendix A. Note that in the case of the forestry residues, composition and dry matter content of hardwood is assumed to be the same as the common Ghanaian specie *Awiefosamina* (*Albizzialucida*) based on Katakai and Konwer (2001) and sawdust is assumed to be 50% trunk wood and 50% bark. The average efficiency of continuous biogas production compared with BMP, η_{scale} , for the forestry residues are assumed to be 50% due to the recalcitrant nature of the biomass. For agricultural residues η_{scale} are assumed to be 80%.

$$y_{biogas}(\text{lignocellulose}) = p_{crop} \cdot Y_{RPR} \cdot (Y_{BUSWEL, glu} \cdot C_{glu} + Y_{BUSWEL, hem} \cdot C_{hem}) \cdot \eta_{Scale} \quad (4)$$

Eqs. (5) and (6) express how the yields of ethanol from lignocellulosic agricultural residue and forestry residues, respectively, were calculated. The crop specific indices have been shown in Table 3 while the general indices assumed for ethanol production are: a 90% conservation of glucan in the pretreatment ($\eta_{pre} = 90\%$) and 80% enzymatic conversion of glucan ($\eta_{enz} = 80\%$). The stoichiometric yields of hydrolysing glucan to glucose ($y_{hyd} = 1.11$ g/g) and fermenting glucose into ethanol ($y_{eth} = 0.51$) are theoretically determined. Ethanol from C5 sugars is not considered and distillation losses are assumed to be negligible.

$$y_{bioethanol}(\text{agriculture}) = p_{crop} \cdot Y_{RPR} \cdot C_{glu} \cdot y_{hyd} \cdot y_{eth} \cdot \eta_{pre} \cdot \eta_{enz} \quad (5)$$

$$y_{bioethanol}(\text{forestry}) = p_{res} \cdot C_{glu} \cdot y_{hyd} \cdot y_{eth} \cdot \eta_{pre} \cdot \eta_{enz} \quad (6)$$

Energy potentials have been converted from Mm³ of methane and ML of ethanol to PJ of heat energy and PJ of liquid energy,

Table 4

Indices of livestock populations (p_{live}), manure produced (y_{man}), the recoverability of the manure (η_{rec}) (KITE, 2008), the total solid concentration (c_{TS}), and the biomethane potential (y_{BMP}).

Type of livestock	p_{live}^a 1000 heads	y_{man}^b kg manure/head/day	η_{rec}^c kg/kg	c_{TS}^d g TS/100 g	y_{BMP}^e m ³ /kg TS
Cattle	1454	12	0.2	12	0.22
Sheep	3759	1.2	0.2	25	0.22
Goats	4855	1.5	0.2	25	0.22
Pigs	536	3.6	0.5	11	0.22
Poultry	47,752	0.02	0.5	25	0.22

^a MOFA (2011).

^b Kartha and Larson (2000), Milbrandt (2009).

^c KITE (2008).

^d Randall et al. (2006).

^e Estimated from Angelidaki and Ellegaard (2003) and Randall et al. (2006).

respectively, using the factors 0.0360 GJ/m³ methane and 22.8 MJ/L ethanol.

4. Results and discussions

4.1. Energy potential from crop and wood residues

The production data for crops in Ghana and the potential residue generated from these crops in 2011 as well as the potential energy from the residues are shown in Table 5. The residue available is dominated by residues from cassava, yam, maize, plantain and groundnut. Together, residue from these five crops constitutes more than 72% of the total residue available. In 2011, the total crop residue generated was approximately 20 Mt. The assumption here is that all processing residues can be available for energy generation as processing involves already concentrated material. An exception to this is cassava peels, of which only 80% are considered available because cassava peels are sometimes fed to livestock or dumped in MSW, depending on the point of usage and the quantities available. For other crops, it is estimated that between 25 and 80% of field based residues could be available for collection in Ghana, depending on the crop. The amount of residues recoverable for energy generation thereby becomes equal to the total agricultural residue generated minus the amount used for other purposes or un-recovered. The potential can be exploited for either biogas or ethanol, or a mixture of the two. The total biogas potential from agricultural residues is approximately 2400 Mm³ of methane containing 83 PJ of heat energy. The total ethanol potential from the residues is estimated to approximately 2300 ML or 51 PJ of liquid fuel energy. Field based residues account for about two thirds of the potential in both the biogas and ethanol case. As the energy content figures show, the conversion to biogas is more efficient than conversion to ethanol. It should be kept in mind, however, that the different energy carriers have different energy qualities, that they can be used for different purposes, and that they therefore are not directly comparable. Also noteworthy is that fact that the estimated ethanol and biogas potentials are based on the technical potential of biomass, but actual potentials could be much lower in practice.

The energy potentials from wood residues in Ghana have been calculated (Table 6). Wood residues are usually available at centralized sites, making it relatively easier to recover significant volumes, which can then be used as feedstock. Currently, wood residues in Ghana are mainly used as firewood and for the production of charcoal. The actual production of residues generated from the manufacture of wood products differs from one plant to another and depends on several factors: from the properties of the wood to the type, operation and maintenance of the processing plant (FAO, 1990). In 2010, about 1.3 Mm³ of industrial roundwood was produced in Ghana (FAO, 2012). Based on estimations deployed by Ghana's Energy Commission (2010), the total amount of slabs,

wane, bark and sawdust from wood residues amounted to about 0.35 Mt. Biogas potential from these residues amounts to 19 Mm³ of methane or 0.67 PJ. Ethanol potential is 48 ML corresponding to 1.1 PJ.

4.2. Energy from animal manure

In terms of quantity, the most important livestock raised in Ghana are cattle, sheep, goats, pigs and poultry (mainly chicken). Populations of livestock in Ghana, the estimated manure, and corresponding energy potentials are shown in Table 7. The majority of cattle are kept free-range during the day and some of them are housed at night. It is therefore assumed that for half the day, manure produced from most cattle is not recoverable. It has also been established that cattle breeds reared in Ghana and many other West African countries are small and undernourished, with less manure production as compared to better fed cattle breeds (KITE, 2008). Sheep and goats are also mostly kept on free range and allowed to stable around farmer residences during the night, which means that only manure produced by night can be collected from these animals. Commercially produced chicken and pigs are largely kept in intensive farming systems. Manure produced from these types of livestock is more easily recoverable as compared to the cattle, sheep and goats. About 100 Mm³ of methane can be produced from the recoverable fraction; this corresponds to 3.6 PJ (Table 7).

4.3. Energy from municipal solid and liquid waste

The potential for energy generation from municipal waste in Ghana has been considered for a while because of its potential dual ability to abate environmental pollution problems (Fobil et al., 2005). Table 8 shows estimates of solid and liquid waste production in the major cities in Ghana. Together, these 11 cities produce about 50% of the solid waste generated in the country due to their large populations. The other half of the waste generated is scattered across over 150 municipalities and districts in the country where collection is not as effective compared to the major cities considered in this paper. Around 2.1 Mt of solid waste and about 0.56 Mt of liquid waste are produced annually in the major cities. About 230 Mm³ methane can be produced from solid waste and about 17 Mm³ of methane from liquid waste (sewage sludge) amounting to a total of 9.0 PJ.

4.4. Discussion

The maximum technical potential of bioenergy from crop residues, wood residues, animal manure, municipal solid wastes and municipal liquid waste in 2011 is 2700 Mm³ of biogas, equivalent to 97 PJ of heat energy, or 2300 ML cellulosic ethanol, equivalent to 52 PJ of liquid fuel energy (Table 9). It is important to note, however, that because of technical constraints cellulosic

Table 5
Energy potential from crop residues in 2011.

Crop	Residue	Theoretical potential of residue	Technical potential of residue	Biogas		Cellulosic ethanol	
		Mt/yr	Mt/yr	Mm ³ CH ₄ /yr	PJ/yr	ML/yr	PJ/yr
Maize	Stalks ^F	2.7	2.2	470	17	410	9.4
	Husks ^P	0.34	0.34	65	2.3	62	1.4
	Cobs ^P	0.49	0.49	140	4.9	86	1.9
Rice	Straw ^F	0.77	0.19	41	1.5	38	0.9
	Husks ^P	0.12	0.12	22	0.8	19	0.4
Millet	Stalks ^F	0.34	0.27	39	1.4	38	0.9
Sorghum	Straw ^F	0.57	0.46	100	3.8	98	2.2
Groundnut	Shells ^P	0.18	0.18	32	1.2	33	0.8
	Straw ^P	1.0	1.0	130	4.6	200	4.5
Cowpea	Shells ^P	0.42	0.42	22	0.8	17	0.4
Cassava	Stalk ^F	0.89	0.71	190	6.7	210	4.7
	Peelings ^P	3.6	0.72	250	9.0	260	5.9
Plantain	Trunks and leaves ^F	1.8	1.5	80	3.0	90	2.0
Soybean	Straw and pods ^F	0.58	0.46	110	3.9	120	2.8
Yam	Straw ^F	3.2	2.5	340	12	330	7.4
Cocoyam	Straw ^F	0.67	0.54	72	2.6	70	1.6
Sweet Potato	Straw ^F	0.022	0.017	2.0	0.1	1.8	0.0
Oil palm	EFB ^P	0.33	0.33	67	2.4	52	1.2
	Kernel shells ^P	0.13	0.13	29	1.0	31	0.7
Coconut	Fibre ^P	0.28	0.28	33	1.2	23	0.5
	Husks ^P	0.12	0.12	14	0.5	14	0.3
Sugarcane	Shells ^P	0.075	0.075	17	0.6	7.8	0.2
	Leaves ^F	0.016	0.013	2.2	0.1	2.2	0.0
	Bagasse ^P	0.025	0.025	4.5	0.2	4.7	0.1
Cotton	Stalks ^F	0.076	0.061	11	0.4	13	0.3
Cocoa beans	Pods ^F	0.84	0.67	43	1.5	37	0.8
Total field based residues				1600	57	1500	35
Total processing residues				750	27	750	17
Total				2400	84	2300	52

^F indicates a field based residue while ^P indicates a processing residue.

Table 6
Energy potential from processing wood residues.

Forestry residue	Production Mt/yr	Biogas		Cellulosic ethanol	
		Mm ³ CH ₄ /yr	PJ/year	10 ⁶ L/yr	PJ/year
Slabs	0.16	10	0.37	28	0.64
Wane	0.061	3.9	0.14	11	0.24
Bark	0.047	1.1	0.039	1.9	0.043
Sawdust	0.081	3.3	0.12	7.9	0.18
Total	0.35	19	0.67	48	1.1

Table 7
Energy potential from animal manure.

Type of livestock	Population 10 ⁶ heads	Estimated amount of manure kg/head/day	Recoverability Fraction g/g	Manure available Mt/yr	Potential biogas Mm ³ CH ₄ /yr	Energy potential PJ/year
Cattle	1.5	12	0.2	1300	34	1.2
Sheep	3.8	1.2	0.2	330	18	0.66
Goats	4.9	2	0.2	710	30	1.1
Pigs	0.54	3.6	0.5	350	8.6	0.31
Poultry	47	0.02	0.5	170	10	0.35
Total					100	3.6

Source: Livestock population data from MOFA (2011); Recoverable fraction estimated from KITE (2008); Manure estimation is from Milbrandt (2009); Kartha and Larson (2000).

Table 8
Energy potential from municipal solid and liquid waste in major cities.

City	Solid waste Mt/yr	Potential biogas Mm ³ CH ₄ /yr	Energy potential PJ/year	Liquid waste Mt/yr	Potential biogas Mm ³ CH ₄ /yr	Energy potential PJ/year
Accra	0.72	80	2.9	0.29	8.7	0.31
Tema	0.5	56	2.0	0.039	1.2	0.043
Kumasi	0.54	60	2.2	0.078	2.4	0.085
Other 8 regional capitals	0.34	37	1.3	0.15	4.6	0.16
Total	2.1	230	8.4	0.56	17	0.61

Source: Municipal waste data from Energy Commission (2010).

Table 9
Summary of energy potential from selected residues in Ghana.

Residue category		Biogas		Cellulosic ethanol	
		Mm ³ CH ₄ /yr	PJ/year	ML ethanol/yr	PJ/year
Crop residue	Field based residue	1600	56	1500	34
	Processing residue	750	27	750	17
Forestry	Processing residue	19	0.67	48	1.1
Manure	Recoverable	100	3.6		
Municipal waste	Solid (MSW)	230	8.4		
	Liquid (MLW)	17	0.61		
Total		2700	97	2300	53

ethanol production is considered only from crop and wood residues whereas biogas production is considered from all residue types discussed in this paper. This selection is done since manure, MSW, and MLW are characterized as being high in water content, low in cellulose content, and with a quite inconsistent composition which significantly complicates industrial implementation of the substrates.

The biogas potential is equivalent to 27% of the heat energy in woodfuel consumed in 2010. In essence, biogas from lignocellulosic materials has the potential to replace approximately 5 Mt of woodfuel. The substitutable share may arguably be higher since combusting biogas is likely to transfer heat more efficiently than in the combustion of wood or charcoal, i.e. 96 PJ in biogas may cook more meals than 96 PJ in woodfuel. The result shows a large potential for biogas production in Ghana. With respect to transport fuels, the total potential of 2300 ML is about seven times the estimated 336 ML of biofuels needed in 2020 to achieve a 10% biofuels blends at the national level.

As emphasized in the methodology, the aforementioned potentials are the maximum bioenergy potentials attainable based on the technical potential of biomass. In practice however, several factors will limit the actual amount of bioenergy than can be produced. Factors such as capital cost of plants, infrastructural development and the skill level of available labor would determine how much biofuel (ethanol or biogas) potential could realistically be implemented. Ethanol potential would be affected by (1) biomass recalcitrance, which varies with maturity, time and method of harvest, extent of drying, and mode of storage, and (2) the cellulose content of biomass after pretreatment, which is dependent on the pretreatment method and process severity, as well as the biomass composition. This is also likely to influence the level of ethanol in the fermentation broth. Also for biogas, the extent to which inoculum is made available to ensure a stable digestion of lignocellulosic waste is a challenge which is linked to the spatial distribution of livestock. These and other factors will affect final bioenergy availability but are not addressed in this paper.

The bioenergy potentials estimated in this study are higher by a factor of one thousand, compared to previous studies on biomass energy in Ghana. [Duku et al. \(2011\)](#) estimated 75.2 TJ heat energy (theoretical potential) from residues of nine major agricultural crops in Ghana using crop production data for 2008. Their study did not provide energy potentials for forestry residues, urban and other wastes considered in this paper. [Mohammed et al. \(2013\)](#) focused on agricultural residue based resources for decentralized energy production. Using methods and data similar to those used by [Duku et al. \(2011\)](#), [Mohammed et al. \(2013\)](#) found that the theoretical energy potential from residues of ten fruits and eight cash crops is 14.6 TJ and 86.6 TJ, respectively. Additionally, 47.6 TJ was calculated as theoretically available from livestock manure. The very large differences in calculated potentials between this study and the ones reported above may be explained by a factor 1000 error in computation in [Duku et al. \(2011\)](#) and [Mohammed](#)

[et al. \(2013\)](#). Assuming that their TJ should be PJ, the findings are comparable.

Many factors affect the decision to choose between using the biomass for biogas or cellulosic ethanol. Even though it is in principle possible to produce both cellulosic ethanol and biogas from most of the residues available, biogas from residues is a much more mature technology as opposed to cellulosic ethanol, which still requires more research. Another characteristic of cellulosic ethanol is that it is much more expensive to produce due to the cost of pretreatment (in terms of energy, solvents, etc.) and the use of enzymes in both saccharification and fermentation. Biogas is more versatile with respect to feedstock as it can be produced from all the residues considered in this paper. Further, biogas conversion more easily allows for local nutrient recycling which could reduce dependence on inorganic fertilizer. On the other hand, ethanol can be used directly as blends in transport fuels without further processing whereas biogas would need further processing to be used as a transport fuel, if there is a desire to do so.

Unlike dung and human feces, lignocellulose is recalcitrant and thus needs some form of pretreatment to disrupt its complex structure and thereby facilitate biological breakdown of cellulose and hemicellulose into simple forms under anaerobic conditions. It should be noted that simple manure-based biodigesters that are mostly promoted in Ghana would need to undergo design changes to handle plant materials that show high propensity to form surface scum, which occludes methane escape, and inhibit the biological process. If all residues considered are used for biogas generation, then the annual biomass potential is capable of supporting biogas production in about 6.1 million household digesters (1.2 m³/day), in 25,000 institutional digesters (300 m³/day), or in 3,600 large-scale plants (2,000 m³/day). The estimated number of domestic plants is more than the number of agricultural households in the country (2.5 million in 2010). Though the possibilities in Ghana's biomass resources appear obvious, moving from estimated potential to implementation and actual output presents huge challenges pertaining to technology and infrastructure.

Compared to biogas there is less experience in the design and installation of hardware required in the cellulosic ethanol production chain: pretreatment, enzymatic hydrolysis, and fermentation. Further, cellulosic ethanol has so far received little attention in the form of funding for research in Africa and thus only a small portion of potential biomass unique to Africa has been studied in detail. From the residues from crops and forest sources, about 180,000 small-scale (12,500 L/y) or 1,800 demonstration units (1.3 ML/y) or 18 commercial-scale plants (120 ML/y) can be technically installed. Apart from the challenge of establishing infrastructure, advances in cellulosic ethanol production will require much effort in research and development along the entire chain – from raw material collection and transportation to ethanol purification – even in small farm-based systems. In the end, the country must decide how to best allocate feedstock between the production of biogas and cellulosic ethanol, based on its long-term energy strategies.

Table A1
Compositional data used for calculating y_{Buswel} and the references for the data.

Crop	Residue	C_{glu} g/100 g TS (starch)	C_{chem} g/100 g TS	Source
Maize	Stalks ^F	36.8	27.4	Amaducci et al. (2000)
	Husks ^P	35.3	21.8	Garlock et al. (2009)
	Cobs ^P	34.0	49.1	Figueiró and Gracioli (2011)
Rice	Straw ^F	37.8	25.3	Jung et al. (2008)
	Husks ^P	31.3	24.3	Leemhuis and de Jong (1997)
Millet	Stalks ^F	26.9	16.5	Chen et al. (2007)
Sorghum	Straw ^F	41.6	26.7	Amaducci et al. (2000)
Groundnut	Shells ^P	35.7	18.7	Leemhuis and de Jong (1997)
	Straw ^P	37.2	n.a.	Samahadthai et al. (2010)
Cowpea	Shells ^P	7.6	7.8	Madhukara et al. (1997)
Cassava	Stalk ^F	33.0	13.0	Martín et al. (2006)
	Peelings ^P	55.5	22.0	Aderemi and Nworgu (2007)
Plantain	Trunks and leaves ^F	34.0	17.0	Thomsen and Schmidt (2012)
Soybean	Straw and pods ^F	38.0	16.0	Richard and Trautmann (2012)
Yam	Straw ^F	25.0	15.0	Estimate
Cocoyam	Straw ^F	25.0	15.0	Estimate
Sweet potato	Straw ^F	19.8	14.6	Dung et al. (2002)
	EFB ^P	30.5	29.9	Shamsudin et al. (2012)
Oil palm	Kernel shells ^P	45.4	21.7	Zhuang et al. (2009)
	Fibre ^P	15.7	19.1	Vadiveloo and Fadel (1992)
Coconut	Husks ^P	21.2	12.7	Bilba et al. (2007)
	Shells ^P	20.0	48.8	Razvigorova et al. (1993)
Sugarcane	Leaves ^F	32.0	17.0	Mellowes et al. (1993)
	Bagasse ^P	36.0	17.0	Shu-Lai and Antal (1992)
Cotton	Stalks ^F	42.0	12.0	Leemhuis and de Jong (1997)
Cocoa	Pods ^F	10.7	8.5	Vadiveloo and Fadel (1992)
	Slabs	58	8	Energy Commission (2010)
Forestry	Wane	58	8	Energy Commission (2010)
	Bark	21	17	Energy Commission (2010)
	Sawdust	40	12	Energy Commission (2010)

^F indicates a field based residue while ^P indicates a processing residue.

5. Conclusions

This paper assessed the potential contribution of bioenergy (biogas and cellulosic ethanol) to meet portions of energy demand in Ghana using residue and waste based biofuels. The types of feedstock considered were crop residues, forestry residue, animal manure and municipal waste. The most important feedstock in terms of energy potential is crop residues. The results show that it is technically possible to obtain Ghanaian biomass for an estimated 2700 Mm³/yr of biogas or 2300 ML/yr of cellulosic ethanol. The biogas potential is sufficient to replace approximately a quarter of Ghana's present woodfuel use. If all the biomass is instead converted to cellulosic ethanol, the estimated potential is seven times the estimated 336 ML of biofuels needed in 2020 to achieve a 10% biofuels blends at the national level.

Projects that aim to produce biogas or cellulosic ethanol in Ghana must ensure sustainability from the feedstock production stage through transport and conversion to final use in order to be viable in the long term. Therefore, the ability of individual bioenergy projects to sustain themselves over time and through changes in the surrounding environmental, social and economic context should be evaluated before decisions are made to develop those projects. Utilizing the bioenergy potential involves an immense challenge of establishing the necessary infrastructure, with small-scale plants counted in hundreds of thousands for cellulosic ethanol and counted in millions for household-scale biogas digesters. The production of cellulosic bioethanol requires more additional research and development to be implemented compared to the more mature biogas technology.

Acknowledgements

This work was supported with a grant from Danida Fellowship Centre (DFC) of the Danish Ministry of Foreign Affairs, as a part

of the project "Biofuel production from lignocellulosic materials – 2GBIONRG", DFC journal no. 10-018RISØ. For additional information, see <http://2gbionrg.dk>.

Appendix A.

See Table A1.

References

- Aderemi FA, Nworgu FC. Nutritional status of cassava peels and root sievate biodegraded with *Aspergillusniger*. *American–Eurasian J Agric Environ Sci* 2007;2(3):308–11.
- Amaducci S, Amaducci MT, Benati R, Venturi G. Crop yield and quality parameters of four annual fibre crops (hemp, kenaf, maize and sorghum) in the North of Italy. *Ind Crop Prod* 2000;11(2/3):179–86.
- Angelidaki I, Ellegaard L. Status and future trends in centralized biogas plants codigestion of manure and organic wastes. *Appl Biochem Biotechnol* 2003;109(1–3):95–105.
- Antwi E, Bensch EC, Quansah DA, Arthur R, Ahiekpor J. Ghana's biofuels policy: challenges and the way forward. *Int J Energy Environ* 2010;1(5):805–14.
- Arthur R, Baidoo MF, Antwi E. Biogas as a potential renewable energy source: a Ghanaian case study. *Renew Energy* 2011;36(5):1510–6.
- Arthur R, Brew-Hammond A. Potential biogas production from sewage sludge: a case study of the sewage treatment plant at Kwame Nkrumah University of science and technology, Ghana. *Int J Energy Environ* 2010;1(6):1009–16.
- Asase M, Yanful EK, Mensah M, Stanford J, Amponsah S. Comparison of municipal solid waste management systems in Canada and Ghana: a case study of the cities of London, Ontario, and Kumasi, Ghana. *Waste Manage* 2009;29(10):2779–86.
- Bensch EC, Brew-Hammond A. Biogas technology dissemination in Ghana: history, current status, future prospects, and policy significance. *Int J Energy Environ* 2010;1(2):277–94.
- Bilba K, Arsene M, Ouensanga A. Study of banana and coconut fibers. *Bioresour Technol* 2007;98(1):58–68.
- Biomass Energy Europe. Status of biomass resource assessments version 3; 2010. Available from: <http://www.eu-bee.info/GetItem.asp?item=digistorefile;247973;837¶ms=open;gallery> (accessed 08.05.13).
- BP (British Petroleum). Excel workbook with historical data; 2012. Available from: <http://www.bp.com/extendedsectiongenericarticle.do?categoryId=9041229&contentId=7075080> (accessed 14.03.13).
- Cai J, Liu R, Deng C. An assessment of biomass resources availability in Shanghai: 2005 analysis. *Renew Sust Energy Rev* 2008;12(7):1997–2004.

- Chen Y, Sharma-Shivappa RR, Keshwani D, Chen C. Potential of agricultural residues and hay for bioethanol production. *Appl Biochem Biotechnol* 2007;142(1):276–90.
- Dasappa S. Potential of biomass energy for electricity generation in sub-Saharan Africa. *Energy Sust Dev* 2011;15:203–13.
- Duku MH, Gu S, Hagan EB. A comprehensive review of biomass resources and bio-fuels potential in Ghana. *Renew Sust Energy Rev* 2011;15(1):404–15.
- Dung NNX, Manh LH, Uden P. Tropical fibre sources for pigs – digestibility, digesta retention and estimation of fibre digestibility in vitro 1996. *Anim Feed Sci Technol* 2002;102(1–4):109–24.
- Edjekumhene I, Agyemang PO, Edze P. Ghana's emerging oil industry: what stakeholders need to know. Kumasi Institute of Technology, Energy and Environment; 2010, Available from: <http://kiteonline.net/images/downloads/emerg.pdf> (accessed 08.02.13).
- Energy Commission. Draft bioenergy policy of Ghana. Energy Commission of Ghana; 2011a.
- Energy Commission. National energy statistics – 2000–2010. Energy Commission of Ghana; 2011b.
- Energy Commission. Renewable energy policy framework for climate change mitigation in Ghana: data for the development of GIS maps, alternative business development scenarios, and toolkit for renewable energy planning and policy. Energy Commission of Ghana; 2010.
- Energy Commission. Strategic national energy plan 2006–2020: main report. Energy Commission of Ghana; 2006, Available from: <http://www.energycom.gov.gh/old/pgs/reports.php> (accessed 15.12.12).
- EU Directive on the promotion of the use of energy from renewable sources. Directive 2009/28/EC of the European Parliament and of the Council of 23 April 2009. *Off J Eur Union* 2009;1–47.
- EU. Proposal for a directive of the European parliament and of the council amending directive 98/70/EC relating to the quality of petrol and diesel fuels and amending directive 2009/28/EC on the promotion of the use of energy from renewable sources; 2012, Available from: <http://ec.europa.eu/energy/renewables/biofuels/doc/biofuels/com.2012.0595.en.pdf> (accessed 19.04.13).
- FAO. Energy conservation in the mechanical forest industries. In: Food and agriculture organisation of the United Nations, FAO forestry paper; 1990. p. 93.
- FAO. Global forest resources assessment. In: Food and agriculture organisation of the United Nations. FAO forestry paper 163; 2010.
- FAO. Ghana timber production; 2012, Available from: <http://faostat3.fao.org/home/index.html#DOWNLOAD> (accessed 05.06.12).
- Fernandes U, Costa M. Potential of biomass residues for energy production and utilization in a region of Portugal. *Biomass Bioenergy* 2010;34:661–6.
- Fobil JN, Carboo D, Armah NA. Evaluation of municipal solid wastes (MSW) for utilisation in energy production in developing countries. *Int J Environ Technol Manage* 2005;5(1):76–86.
- Garlock RJ, Chundawat SPS, Balan V, Dale BE. Optimizing harvest of corn stover fractions based on overall sugar yields following ammonia fiber expansion pretreatment and enzymatic hydrolysis. *Biotechnol Biofuels* 2009;2(2):29.
- Gopalakrishnan G, Negri MC, Wang M, Wu M, Snyder SW, Lafreniere L. Biofuels, land, and water: a systems approach to sustainability. *Environ Sci Technol* 2009;43(15):6094–100.
- GRIDCO (Ghana Grid Company Limited). Ghana transmissions and distribution master plan. Ghana grid company study; 2011.
- Gunaseelan VN. Anaerobic digestion of biomass for methane production: a review. *Biomass Bioenergy* 1997;13(1):83–114.
- Gustavsson L, Holmberg J, Dornburg V, Sathre R, Eggers T, Mahapatra K, et al. Using biomass for climate change mitigation and oil use reduction. *Energy Policy* 2007;35(11):5671–91.
- Hirsch RL, Bezdek R, Wendling R. Peaking of world oil production: impacts, mitigation, & risk management. Science Applications International Corporation/U.S. Department of Energy, National Energy Technology Laboratory; 2005.
- IPCC (Intergovernmental Panel on Climate Change). IPCC working groups contributions to the fourth assessment report (AR4); 2007, Available from: <http://www.ipcc.ch> (accessed 19.03.13).
- IEA (International Energy Agency). Sustainable production of second-generation biofuels: potential and perspectives in major economies and developing countries. Information paper, Paris, France; 2010.
- IEA (International Energy Agency). World energy outlook; 2012, Available online from: <http://www.iea.org/> (accessed 14.02.13).
- IEA Bioenergy. From 1st- to 2nd-generation biofuel technologies: an overview of current industry and R&D activities. Paris, France: IEA Bioenergy; 2008.
- Jekayinfa SO, Scholz V. Potential Availability of Energetically Usable Crop Residues in Nigeria, Energy Sources, Part A: Recovery. *Util Environ Eff* 2009;31(8):687–97.
- Junfeng L, Runqing H, Yanqin S, Jingli S, Bhattacharya SC, Abdul Salam P. Assessment of sustainable energy potential of non-plantation biomass resources in China. *Biomass Bioenergy* 2005;29:167–77.
- Jung SH, Kang BS, Kim JS. Production of bio-oil from rice straw and bamboo sawdust. *J Anal Appl Pyrol* 2008;82:240–7.
- Kartha S, Larson ED. Bioenergy primer: modernised biomass energy for sustainable development. UNDP; 2000, Available from: <http://www.undp.org/content/dam/aplaws/publication/en/publications/environment-energy/www-ee-library/sustainable-energy/bioenergy-primer-modernised-biomass-energy-for-sustainable-development/Bioenergy%20Primer.2000.pdf> (accessed 19.03.13).
- Kataki R, Konwer D. Fuelwood characteristics of some indigenous woody species of north-east India. *Biomass Bioenergy* 2001;20(2):17–23.
- KITE (Kumasi Institute of Technology, Energy and Environment). Feasibility study report on domestic biogas in Ghana – report submitted by Kumasi Institute of Technology, Energy and Environment (KITE) to the Shell Foundation; 2008.
- KITE (Kumasi Institute of Technology, Energy and Environment). Biomass energy for rural development: an assessment of the feasibility of using agricultural residues and municipal wastes to produce modern energy services in selected communities in the eastern region of Ghana. Final report submitted to American Physical Society; 2009.
- Kludze H, Deen B, Weersink A, Van Acker R, Janovicek K, De Laporte A. Assessment of the availability of agricultural biomass for heat and energy production in Ontario. In: A report for the Ontario Ministry of Agriculture, Food and Rural Affairs; 2010, Available from: http://www.uoguelph.ca/plant/research/agronomy/publications/pdf/Ontario_Biomass_Availability_Project_Final_Report_2011.01.27.pdf (accessed 19.03.2013).
- Koopmans A, Koppejan J. Agricultural and forest residues – generation, utilization and availability. In: Paper presented at the regional consultation on modern applications of biomass energy; 1997.
- Lamers P, Hamelinck C, Junginger M, Faaij A. International bioenergy trade—a review of past developments in the liquid biofuel market. *Renew Sust Energy Rev* 2011;15:2655–76.
- Leemhuis RJ, de Jong RM. Biomassa: biochemischesamenstelling en conversiemethoden (confidential report, in Dutch), Petten, ECN, ECN 7.2072-GR 2; 1997. p. 16.
- Lemke RL, Van den Bygaart AJ, Campbell CA, Lafond GP, Grant B. Crop residue removal and fertilizer N: effects on soil organic carbon in a long-term crop rotation experiment on a Udic Boroll. *Agric Ecosyst Environ* 2010;135:42–51.
- Madhukara K, Sripatha HR, Srinath K, Bharathi K, Krishna N. Production of methane from green pea shells in floating dome digesters. *Process Biochem* 1997;32(6):509–13.
- Martin C, Lopez Y, Plasencia Y, Hernandez E. Characterisation of agricultural and agro-industrial residues. *Chem Biochem Eng Q* 2006;20(4):443–7.
- Mellowes WA, Inkim C, Phil M, Jaharaj D. Evaluation of hydrolysis methods for conversion of selected tropical biomass to fuel ethanol. In: Klass DL, editor. Proceedings of Energy from Biomass and Wastes XVI. Chicago, IL: Institute of Gas Technology; 1993. p. 599–628.
- Milbrandt A. Assessment of biomass. Resources in Liberia. Prepared for the U.S. Agency for International Development (USAID) under the Liberia Energy Assistance Program (LEAP). Technical report NREL/TP-6A2-44808; 2009.
- Ministry of Energy. Renewable energy policy and regulatory framework and renewable energy law for Ghana – electricity generation, vol. 1. Accra, Ghana: Ministry of Energy; 2012.
- MOFA. Agriculture in Ghana: facts and figures 2010. Ministry of Food and Agriculture, Government of Ghana; 2011.
- Mohammed YS, Mokhtar AS, Bashir N, Saidur R. An overview of agricultural biomass for decentralized rural energy in Ghana. *Renew Sust Energy Rev* 2013;20:15–22.
- Randall J, Maurice LE, Larry CB, Kevin HE, Stephen SF, James JH, et al. Ohio Livestock Manure Management Guide. Ohio State University Extension; 2006. p. 1–117, Available from <http://agcrops.osu.edu/specialists/fertility/fertility-fact-sheets-and-bulletins/bulletin.604.pdf>
- Razvigorova M, Goranova M, Minkova V, Cerny J. On the composition of volatiles evolved during the production of carbon adsorbents from vegetable wastes. *Fuel* 1993;73(11):1718–22.
- Richard T, Trautmann N. Substrate composition table. Ithaca, NY: Cornell University; 2006, Available from: <http://compost.css.cornell.edu/calc/lignin.noframes.html> (accessed 27.11.12).
- Samahadthai P, Vityakon P, Saenjan P. Effects of different quality plant residues on soil carbon accumulation and aggregate formation in a tropical sandy soil in northeast Thailand as revealed by a 10-year field experiment. *Land Degrad Dev* 2010;21(5):463–73.
- Shamsudin S, Md Shah UK, Zainudin H, Abd-Aziz S, Kamal SMM, Shirai Y, Hassan MA. Effect of steam pretreatment on oil palm empty fruit bunch for the production of sugars. *Biomass and Bioenergy* 2012;36:280–8.
- Smeets E, Faaij A, Lewandowski I. A quickscan of global bioenergy potentials to 2050. In: An analysis of the regional availability of biomass resources for export in relation to the underlying factors. Report NWS-E-2004-109. Netherlands: Utrecht University; 2004, Available from: http://www.riaed.net/IMG/pdf/A_quickscan_of_global_bioenergy_potentials_to_2050.pdf (accessed 19.03.13).
- Smeets E, Faaij A, Lewandowski I, Turkenburg W. A bottom-up assessment and review of global bio-energy potentials to 2050. *Prog Energy Combust* 2007;33:56–106.
- Shu-Lai M, Antal MJ. Uncatalyzed solvolysis of whole biomass hemicellulose by hot compressed liquid water. *Ind Eng Chem Res* 1992;31(4):1157–61.
- Thomsen ST, Schmidt JE. 2nd Generation biofuel production from selected agricultural waste resources in Ghana. In: Poster presented at the conference of advanced biofuels in a biorefinery approach; 2012.
- US Government. Energy independence and security act of 2007. Public law; 2007. p. 110–40.
- Vadiveloo J, Fadel JG. Compositional analyses and rumen degradability of selected tropical feeds. *Anim Feed Sci Technol* 1992;37(3–4):265–79.
- Zheng YH, Li ZF, Feng SF, Lucas M, Wu GL, Li Y. Biomass energy utilization in rural areas may contribute to alleviating energy crisis and global warming: a case study in a typical agro-village of Shandong, China. *Renew Sust Energy Rev* 2010;14(9):3132–9.
- Zhuang X, Yuan Z, Ma L, Wu C, Xu M, Xu J. Kinetic study of hydrolysis of xylan and agricultural wastes with hot liquid water. *Biotech Adv* 2009;27(5):578–82.